

Bellman Visit Door Transmitter

BE1023



Function

The BE1023 Bellman Visit Door Transmitter is a transmitter within the Bellman Visit System for indoor use, which recognises the sound emitted by a doorbell. If the doorbell is electromechanical, the Door transmitter also detects the electromagnetic field emitted by the doorbell.

Installation & connection

The unit is generally installed on a wall or door. It is mounted using the factory-fitted, self-adhesive Velcro tape or with the wall bracket and screw supplied.

For best results, the Bellman Visit Door Transmitter should be placed as close as possible to, or just under, the left of the doorbell at a maximum distance of 3 cm.

The unit is connected to the Bellman Visit System by radio. For further information see Settings.

It is activated via the built-in microphone (4) and/or the built-in magnetic coil.

Testing

To test the Bellman Visit Door Transmitter's radio transmitter, the Bellman Visit receiver must be tuned to the same channel as the Door transmitter.

- Now press test button (2)
- The receiver will indicate whether there is an alarm from the Bellman Visit Door Transmitter.

Testing the microphone:

- The microphone can be tested by ringing the doorbell.
- The Bellman Visit Door Transmitter will respond by lighting the green LED (1).

Testing the magnetic coil:

- The magnetic coil can be tested by turning off the microphone with switch 2 of the tone switch (5) (see Functions below).
- Ring the electromechanical doorbell positioned as set out in the above instructions.
- The Bellman Visit Door Transmitter will respond by lighting the green LED (1).

Technical information

Power supply

Battery: 9 V 6LR61 Alkaline
9 V 6F22 Lithium

Operating time:

6LR61 Alkaline: approximately 5 years
6F22 Lithium: approximately 10 years

Power consumption:

Active: 15 mA
Idle position: <0.1mA

Radio function

Radio frequency: 433.92 MHz

Number of channels: 64 logical channels

Coverage: The normal coverage between a transmitter and receiver in the Bellman Visit System is approximately 80 metres with a clear line of sight. Coverage is reduced if walls and large objects screen off the signal. Any thick walls constructed of reinforced concrete will greatly affect coverage.

Activation via

The in-built microphone and in-built magnetic coil

Test button

Additional information

For indoor use only

Dimensions WxHxD: 80 x 145 x 36 mm

Weight: With battery: 210 g
Without battery: 160 g

Colour: White with a red triangle

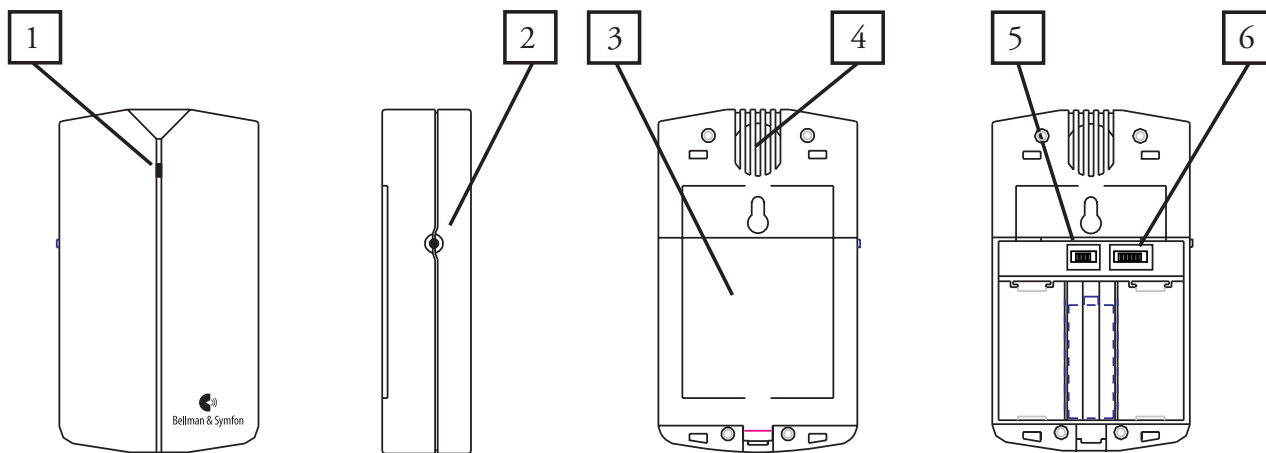

- 1. LED
- 2. Test button
- 3. Battery cover
- 4. Microphone
- 5. Tone switch
- 6. Channel switch

Indicators

Visit functions

When green LED (1) lights, the unit is transmitting a radio signal.

Power supply

When LED (1) lights up green and red simultaneously, the unit is transmitting a radio signal but the batteries are flat and need to be changed. Only use alkaline or lithium batteries.

Settings

Changing the radio channel

All Bellman Visit System units are supplied from the factory tuned to the same channel, channel 0. This means that all radio channel switches on the transmitter are set to the 'off' position.

- To alter the channel, move the channel switches (6) to the desired position.

⚠ Please note:
 All Bellman Visit products within the same system must be tuned to the same channel in order to operate as a group. The only exception is the Bellman Visit Fire Alarm Transmitter, which does not have adjustable channels. As a safety precaution, the Visit System receiver will sound when a fire alarm signal is detected, regardless of the channel to which the receiver has been programmed.



Functions

Use the tone switch (5) to select the following settings for the BE1023:



Switch (1)	Alters the receiver's ring signal and vibration so that two Door transmitters can be used in one Bellman Visit System, see below.
Switch (2)	Turns off the microphone so that only electromagnetic doorbells can be detected. Useful in noisy environments. On (up) = Microphone off Off (down) = Microphone on
Switch (3)	Increases sensitivity to the electromagnetic field from the electromechanical doorbell. On (up) = Extra sensitivity Off (down) = Normal sensitivity
Switch (4)	Turns off the magnetic coil so that only acoustic ring signals can be detected. This is useful if the electromagnetic field from an inductive loop or transformer, etc., activates the Door transmitter. On (up) = Electromagnetic sensor off Off (down) = Electromagnetic sensor on

Indication and signal from receiver when activated.

DIP switch settings Up, Down, Not Used	Sound	LED	Vibration
 On (up)	2 x ding dong	Orange LED	Long vibration
 Off (down)	1 x ding dong	Green LED	Long vibration

Troubleshooting

Problem:	Solution:
The LED on the front does not light even when the test button is pressed.	Change the battery. Only use lithium or alkaline batteries. Used batteries should be handed in to a battery collection point in accordance with national regulations.
The LED on the front lights up red and green simultaneously when the doorbell rings.	Change the battery. Only use lithium or alkaline batteries. Used batteries should be handed in to a battery collection point in accordance with national regulations.
The Door transmitter does not activate when the doorbell rings.	1. The Door transmitter is too far away from the doorbell or on the right-hand side of the doorbell. Move the Door transmitter around to find out where it operates best. 2. The sensitivity to electromechanical doorbells can be increased by moving switch 3 on the tone switch (5) into the upper position.
The Door transmitter functions and the LED on the front lights up green when the doorbell rings but the receivers are not activated.	1. Check the receiver batteries. 2. Check that the receivers are tuned to the same channel as the Door transmitter. 3. Check that the receiver is not placed too far away by moving the receiver closer to the transmitter.
The Door transmitter activates even when there is no ring at the door.	1. Turn off the magnetic coil if an electromagnetic field from an inductive loop, etc., is causing activation. 2. Turn off the microphone if background noise is causing activation.